

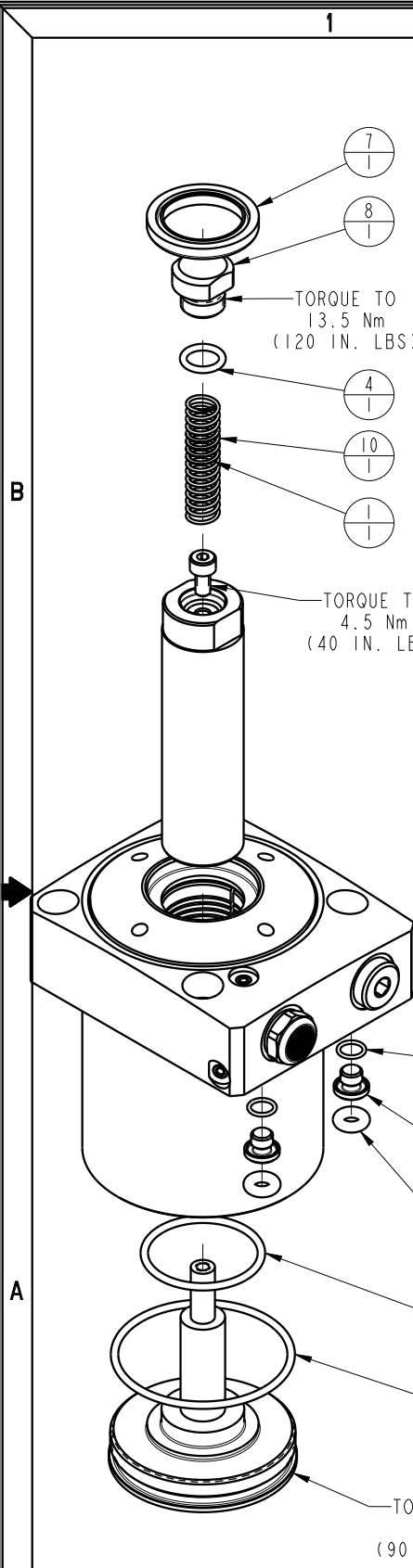

NO	QTY	PART NO	DESCRIPTION	STD SEAL KIT	LIGHT SPRING KIT	HEAVY SPRING KIT
1	1	23350126	SPRING, COMPRESSION			X
2	2	39051079	O-RING, (6mm X 1)	X		
3	2	39051087	O-RING, (4mm X 3)	X		
4	1	39051132	O-RING, (8.75mm X 1.8)	X	X	X
5	1	39051133	O-RING, (45.5mm X 2)	X		
6	1	39051137	O-RING, (29.5mm X 2)	X		
7	1	39053056	WIPER, PRESS-IN, 22mm	X		
8	1	81000052	CONTACT BOLT, WS, 7MPa, 16 & 26kN			
9	2	81400200	PLUG, MANIFOLD, 7MPa, M6			
10	1	23350125	SPRING, COMPRESSION		X	
N/A	N/A	L6010010	KIT, SEAL, WS, 7MPa, TF, SPR, 26kN	NOTED	N/A	N/A
N/A	N/A	L6110024	KIT, SPRING, WS, 7MPa, SPR, 26kN	N/A	NOTED	N/A
N/A	N/A	L6110025	KIT, SPRING, WS, 7MPa, SPR, 26kN	N/A	N/A	NOTED
N/A	N/A	ISL1014	INSTRUCTION SHEET, WS, 7MPa, TF, SPR, 26kN	N/A	N/A	N/A



See Instruction Sheet ISL1014 For Service Instructions.
 Lubricate All Seals With Clean Hydraulic Oil Prior To Assembly.
 Do Not Use Silicone Base Lubricants.



PARTS LIST	 VEKTEK VEKTEK, INC. 1334 E. SIXTH AVE. P.O. BOX 625 EMPORIA, KS. 66801 U.S.A.
	PARTS LIST, ASSY, WS, 7MPa, TF, SPR, 26kN
ASSEMBLIES AFFECTED L1-0122-00H L1-0122-00L	SIZE A LPL1022
REV B	REV B

B	3849	RELEASE	MJUST	7/8/19
REV	IN ACCORDANCE WITH ECN	EFFECTIVE DATE	REVISED BY	DATE
DRW BY:	N. KARRAS	DRAWING STATUS: Released		
DATE:	03/20/14	PRODUCTION APPROVED FOR RELEASED STATUS ONLY		

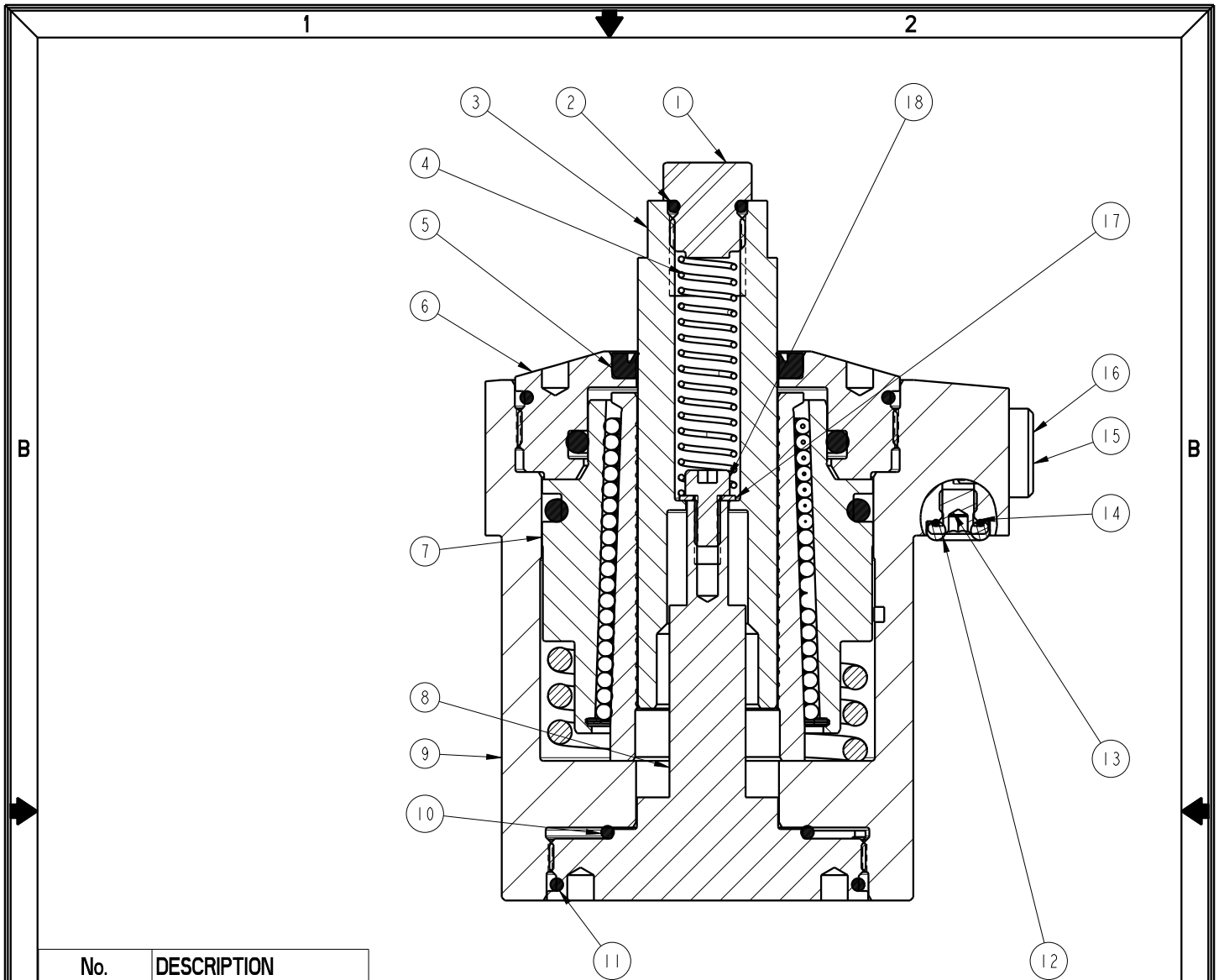

No.	DESCRIPTION
1	CONTACT BOLT
2	O-RING (8.75 mm X 1.8)
3	PLUNGER
4	SPRING
5	WIPER
6	TOP CAP
7	COLLET ASSY
8	BOTTOM CAP
9	BODY
10	O-RING (29.5 mm X 2)
11	O-RING (45.5 mm X 2)
12	O-RING (4 mm X 3)
13	MANIFOLD PLUG
14	O-RING (6 mm X 1)
15	G1/8 PLUG
16	BREATHER
17	WASHER
18	SHCS

TOOL LIST			
<input type="checkbox"/>	14mm & 19mm Open End Wrench		
<input type="checkbox"/>	3mm Hex Key		
<input type="checkbox"/>	Vekttek # ATL10323 Spanner Wrench		

INSTALLATION INSTRUCTIONS

VEKTEK, INC.
 1334 E. SIXTH AVE. P.O. BOX 625
 EMPORIA, KS. 66801 U.S.A.

B	3141	RELEASE	NJK	11/15/16
REV	IN ACCORDANCE WITH ECN	EFFECTIVE DATE	REVISED BY	DATE
DRW BY:	N. KARRAS	DRAWING STATUS: Released		
DATE:	05/16/16	PRODUCTION APPROVED FOR RELEASED STATUS ONLY		

ASSEMBLIES AFFECTED
 LI-0122-00H
 LI-0122-00L

INSTRUCTION SHEET, WS, 7MPo, TF, SPR, 26kN			
SIZE	ISLI014	REV	B

FORM FEG041-1S.AS1ZE, REV. B

SHEET 1 OF 3

Read all instructions before disassembly

Refer to the illustration on page 1 for component part numbers and tool list

Disassembly

1. Remove work support from fixture. Wipe clean to remove external contaminants.
2. With 19mm wrench at plunger (3) and 14mm wrench at contact bolt (1), unscrew contact bolt (1) from plunger (3). Remove O-ring (2) from contact bolt (1).
3. Remove contact spring (4) from inside plunger (3).
4. Insert 3 mm hex key into cap screw (18) inside plunger (3) and unscrew cap screw (18). Remove cap screw (18) and washer (17) from inside plunger (3).
5. Gently slide plunger (3) out from top of work support.

Caution: Do not expose work support clamping mechanism (7) located underneath the top cap (6) to any type of cleaning solutions. Removal of top cap (6) or clamping mechanism (7) terminates product warranty.

6. Clamp work support body (9) in vise with bottom side facing up.
7. Using Vektek #ATL10323 spanner wrench, unscrew bottom cap (8) from work support body (9). Remove O-ring (10) and O-ring (11) from bottom cap (8).
8. Remove work support body (9) from vise.
9. Remove wiper (5) from top cap (6). Be careful not to damage wiper bore or bore below wiper (5).
10. If work support hydraulics are manifold fed from fixture, remove O-ring (12) from manifold port of work support (9) mounting flange (2 places).
11. If work support hydraulics are not manifold fed from fixture, insert 3 mm hex key into plug (13) located at manifold port of work support (9) mounting flange and unscrew plug (13) (2 places). Remove O-ring (14) from plug (13).
12. Thoroughly clean contact bolt (1), contact spring (4), plunger (3), cap screw (18), washer (17), bottom cap (8), plugs (13) and set aside to dry.
13. Wipe clean bottom cap seal bore and seal face located in bottom of body (9). Wipe clean wiper bore located in top cap (6) at top of work support. Wipe clean manifold ports located on body (9) mounting flange.

		
VEKTEK, INC. 1334 E. SIXTH AVE. P.O. BOX 625 EMPORIA, KS. 66801 U.S.A.		
INSTRUCTION SHEET, WS, 7MPo, TF, SPR, 26kH		
SIZE A	ISL1014	REV B
FORM FEG041-IS.ASIZE, REV. B		

Assembly

1. Lubricate new O-rings (2), (10), (11), (12), (14) and outside diameter of new wiper (5) with clean hydraulic oil (Vektek 65-0010-01 or equivalent). Also, apply light film of hydraulic oil to outside surface of plunger (3).
2. Press wiper (5) into top cap (6) taking extra care to install squarely without excess force. CAUTION: IMPROPER INSTALLATION COULD DAMAGE WIPER (5) CAUSING EXCESS WIPER DRAG.
3. Install O-ring (10) and O-ring (11) onto bottom cap (8)
4. Clamp work support body (9) into vise with bottom side facing up.
5. Screw bottom cap (8) into bottom of work support body (9). Using Vektek #ATL10323 spanner wrench, torque bottom cap (8) to 120 N-m (90 ft-lb).
6. Remove work support body (9) from vise and position with top cap (6) upward.
7. Gently install plunger (3) into work support through wiper (5) taking care not to damage wiper (5). Plunger (3) should move freely without binding. Lightly push plunger (3) downward until bottoms.
8. Install washer (17) onto cap screw (18) dropping thread side down through top of plunger (3). Insert 3 mm hex key into cap screw (18) and torque to 4.5 N-m (40 in-lb).
9. Insert contact spring (4) into hole through top of plunger (3). Contact spring (4) will pilot onto cap screw (18).
10. Install O-ring (2) onto contact bolt (1).
11. Screw contact bolt (1) into top of plunger (3). With 19 mm wrench at plunger (3) and 14 mm wrench at contact bolt (1) torque to 13.5 N-m (120 in-lb).
12. If work support hydraulics are manifold fed from fixture, install new O-ring (12) into manifold port of work support body (9) mounting flange (2 places).
13. If work support hydraulics are not manifold fed from fixture, install O-ring (14) onto plug (13), insert 3mm hex key into plug (13) and torque to 3 N-m (25 in-lb) (2 places).

		
VEKTEK, INC. 1334 E. SIXTH AVE. P.O. BOX 625 EMPORIA, KS. 66801 U.S.A.		
INSTRUCTION SHEET, WS, 7MPo, TF, SPR, 26kN		
SIZE A	ISLI014	REV B
FORM FEG041-1S-ASIZE, REV. B		

SHEET 3 OF 3